

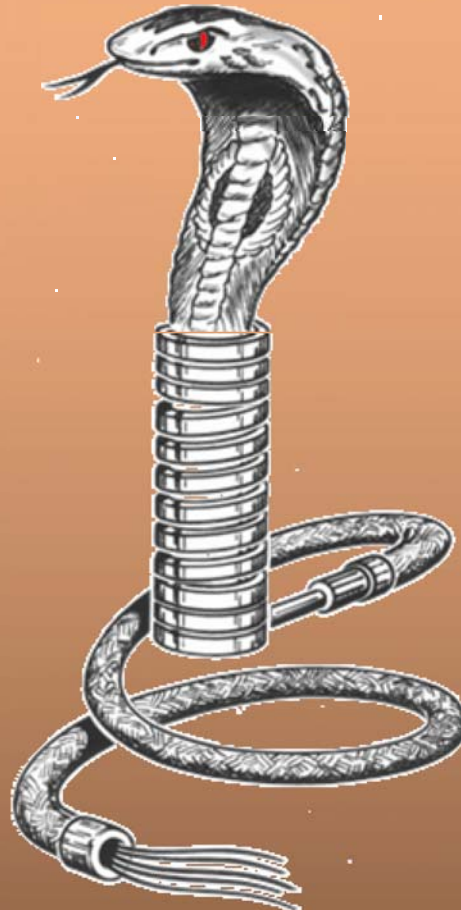

# **MARATHON HEATER**



**VIPER**

**COIL HEATERS**



# VIPER COIL HEATER STANDARD FEATURES

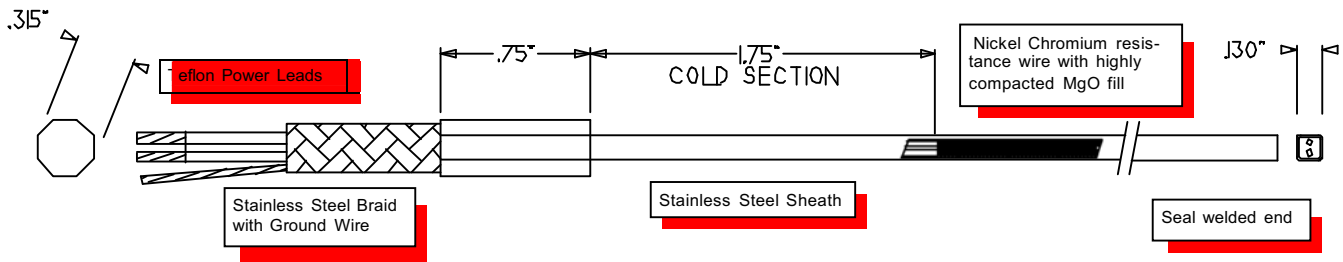

Internal Type J and Type K thermocouples are available for precise temperature control.

.130 square cross section is standard.

Other lead arrangements are available.

## STANDARD VIPER COIL SIZES

The adjacent table shows the standard lengths and wattages that are available off the shelf for coiling and immediate delivery. Heaters can be coiled to lengths greater than shown with or without wattage profiling. Coil lengths can be much longer than those shown depending on coil spacing. Heaters can normally be coiled and shipped in one working day.

Coil lengths based on a closed coil. Coils can be stretched for distributed wattage and/or much longer coil lengths.

Sizes are based on a 1.18" extension length.

All heaters are 240V.

All heaters have 36" leads with stainless steel overbraid and a ground wire.

Heaters are available with and without thermocouple.

All heaters are .13" x .13" square cross section.

### STRAIGHT LTH vs. COIL LTH

Straight Length	Wattages Available	Coil Diameter (ID)							
		1/2	5/8	3/4	7/8	1	1 1/4	1 1/2	
14	200	-	1.02	0.88	0.75	0.75	0.61	0.47	0.47
16	250	175	1.16	1.02	0.88	0.75	0.75	0.61	0.47
18	300	225	1.31	1.16	1.02	0.88	0.75	0.61	0.61
20	350	250	1.45	1.18	1.04	0.90	0.90	0.77	0.63
24	400	300	1.74	1.47	1.33	1.20	1.06	0.92	0.79
28	450	350	2.04	1.76	1.49	1.35	1.22	1.08	0.94
32	500	400	2.31	1.90	1.76	1.49	1.35	1.22	0.94
36	600	450	2.62	2.21	1.93	1.66	1.52	1.25	1.11
40	700	500	2.90	2.49	2.08	1.94	1.67	1.39	1.26
48	800	550	3.47	2.92	2.51	2.24	2.10	1.69	1.55
52	900	650	3.76	3.21	2.80	2.53	2.26	1.84	1.57
56	1000	-	4.04	3.49	2.94	2.67	2.39	1.98	1.71
64	1100	-	4.58	3.90	3.25	2.94	2.67	2.26	1.98
72	1250	-	5.13	4.31	3.76	3.35	2.94	2.53	2.12
80	1400	1000*	5.68	4.86	4.17	3.63	3.35	2.80	2.39
100	1100*	-	7.52	6.42	5.28	4.53	4.18	3.50	2.98
118	1200*	-	8.88	7.16	5.99	5.19	4.52	3.69	3.08

\* Only available with TC

## STANDARD LEAD ORIENTATIONS

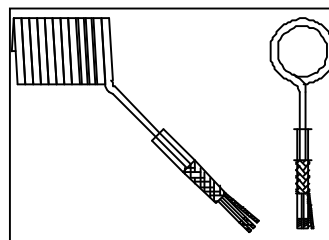
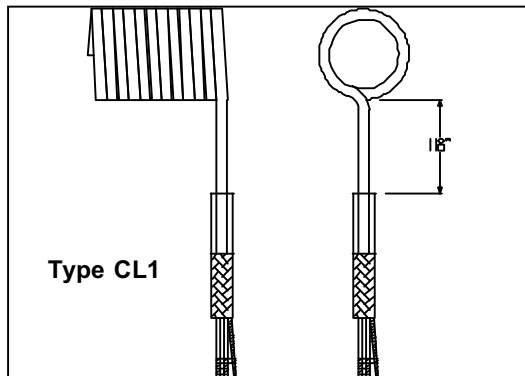

Other configurations available upon request.

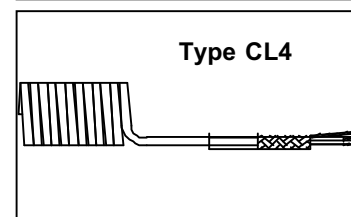
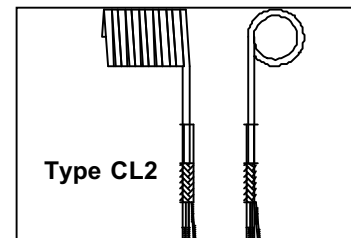

## OEM REPLACEMENT HEATERS

OEM Part No.	Marathon Part No.	Coil ID	Coil Length	Lead Length	TC	Volts	Watts
SCH0001	CL125-027A	1.25	2.70	36	NO	240	800
SCH0002	CL125-017A	1.25"	1.70	36	NO	240	600
SCH0003	CL62-009A	0.625"	0.975	36	NO	240	225
SCH0060	CL75-014A	0.750"	1.437	36	NO	240	250
SCH0061	CL75-019A	0.750"	1.937	36	NO	240	300
SCH0062	CL75-024A	0.750"	2.437	36	NO	240	350
SCH0063	CL75-029A	0.750"	2.937	36	NO	240	400
SCH0064	CL75-034A	0.750"	3.437	36	NO	240	425
SCH0065	CL75-044A	0.750"	4.437	36	NO	240	500
SCH0066	CL75-054A	0.750"	5.437	36	NO	240	500
SCH0081	CL62-020A	0.625"	2	36	YES	240	300
SCH0082	CL62-025A	0.625"	2.5	36	YES	240	350
SCH0083	CL62-030A	0.625"	3	36	YES	240	400
SCH0084	CL62-035A	0.625"	3.5	36	YES	240	425
SCH0085	CL62-040A	0.625"	4	36	YES	240	500
SCH0086	CL62-050A	0.625"	5	36	YES	240	500
SCH0087	CL62-060A	0.625"	6	36	YES	240	550
SCH0088	CL87-021A	0.875"	2.125	36	YES	240	400
SCH0089	CL87-026A	0.875"	2.625	36	YES	240	450
SCH0090	CL87-031A	0.875"	3.125	36	YES	240	550
SCH0091	CL87-036A	0.875"	3.625	36	YES	240	700
SCH0092	CL87-041A	0.875"	4.125	36	YES	240	800
SCH0093	CL87-051A	0.875"	5.125	36	YES	240	900
SCH0094	CL87-061A	0.875"	6.125	36	YES	240	1000
SCH0095	CL87-071A	0.875"	7.125	36	YES	240	1100
SCH0096	CL150-040B	1.500"	4.00	36	YES	240	1000
SCH0097	CL150-050A	1.500"	5.00	36	YES	240	1000
SCH0098	CL150-060A	1.500"	6.00	36	YES	240	1100
SCH0099	CL150-070A	1.500"	7.00	36	YES	240	1100
SCH0100	CL150-080A	1.500"	8.00	36	YES	240	1200
SCH0101	CL150-090A	1.500"	9.00	36	YES	240	1200
SCH0102	CL150-100A	1.500"	10.00	36	YES	240	1200
SCH3142	CL75-014A	0.750"	1.75	36	YES	240	315
SCH3242	CL75-024B	0.750"	2.44	36	YES	240	315

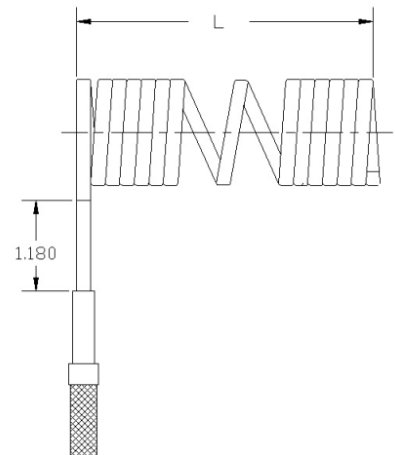

OEM Part No.	Marathon Part No.	Coil ID	Coil Length	Lead Length	TC	Volts	Watts
SSTC-31-90	CL50-045F	0.500"	4.625"	36	YES	240	300
SSTC-32-90	CL50-045D	0.500"	4.625"	36	YES	240	300
SSTC-42-90	CL50-025B	0.500"	2.50"	36	YES	240	450

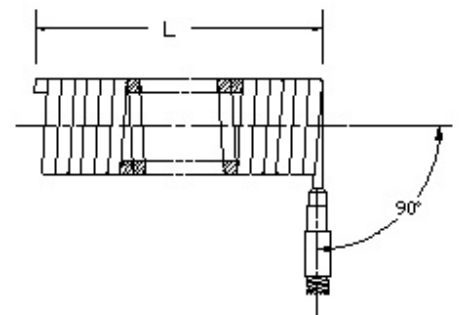

OEM Part No.	Marathon Part No.	Coil ID	Coil Length	Lead Length	TC	Volts	Watts
SSTC-31	CL50-045E	0.500"	4.625"	36	YES	240	300
SSTC-32	CL50-045C	0.500"	4.625"	36	YES	240	300
SSTC-42	CL50-025A	0.500"	2.50"	36	YES	240	450

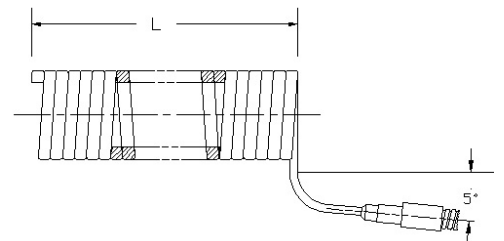

OEM Part No.	Marathon Part No.	Coil ID	Coil Length	Lead Length	TC	Volts	Watts
SCH1060	CL075-015C	0.750"	1.594"	36	YES	240	250
SCH1061	CL075-020G	0.750"	2.094"	36	YES	240	300
SCH2061	CL075-020H	0.750"	2.094"	36	YES	240	300
SCH1062	CL075-025A	0.750"	2.594"	36	YES	240	350
SCH2062	CL075-025B	0.750"	2.594"	36	YES	240	350
SCH1063	CL075-030D	0.750"	3.094"	36	YES	240	400
SCH2063	CL075-030E	0.750"	3.094"	36	YES	240	400
SCH1064	CL075-035B	0.750"	3.594"	36	YES	240	425
SCH2064	CL075-035C	0.750"	3.594"	36	YES	240	425
SCH1065	CL075-045A	0.750"	4.594"	36	YES	240	500
SCH2065	CL075-045B	0.750"	4.594"	36	YES	240	500
SCH1066	CL075-055A	0.750"	5.594"	36	YES	240	500
SCH2066	CL075-055B	0.750"	5.594"	36	YES	240	500
SSTC-62-90	CL50-014A	0.500"	1.45"	36	YES	240	250
SSTC-72-90	CL50-020C	0.500"	2.00"	36	YES	240	250

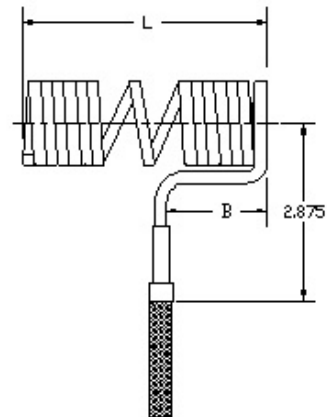

OEM Part No.	Marathon Part No.	Coil ID	Coil Length	Lead Length	TC	Volts	Watts
SCH0103	CL075-010C	0.750"	1.0"	36	NO	240	125
SCH0104	CL075-010D	0.750"	1.0"	72	NO	240	125
SCH0105	CL075-010E	0.750"	1.0"	36	NO	240	250
SCH0106	CL075-010F	0.750"	1.0"	72	NO	240	250
SCH0107	CL075-010G	0.750"	1.0"	36	YES	240	125
SCH0108	CL075-010H	0.750"	1.0"	36	NO	240	250
SCH0109	CL087-010A	0.875"	1.0"	36	NO	240	125
SCH0110	CL087-010B	0.875"	1.0"	36	NO	240	250

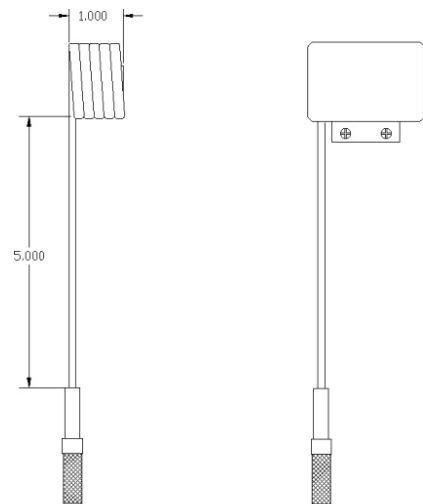

**Marathon Heater (India) Pvt. Ltd.**  
 190A, Road No. 5, M.I.A., Madri,  
 Udaipur (Raj.) – India  
 Ph – 0294-3057700 - 800  
 Fax – 0294-3057750  
 Email – info@marathonheater.in  
 Website – www.marathonheater.in

